

Circuit Diagram

(1) Line to ground capacitor code : 223, 683, 104

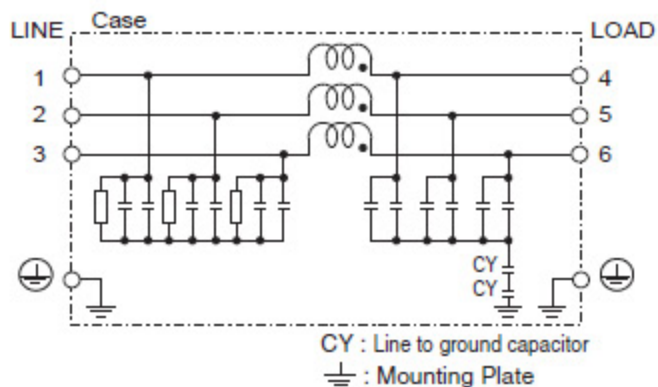

(2) Line to ground capacitor code : 155, 335

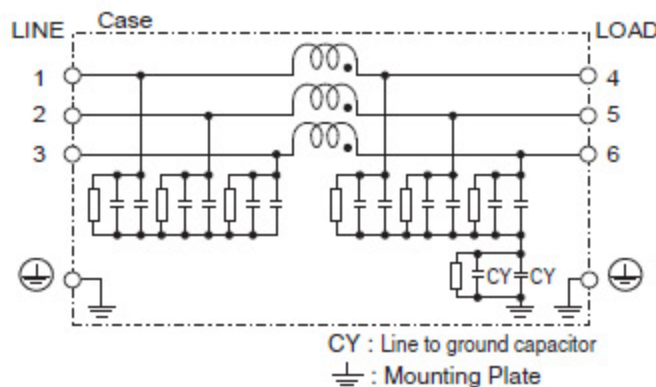

(3) Line to ground capacitor code : 223, 683, 104
 Option : U

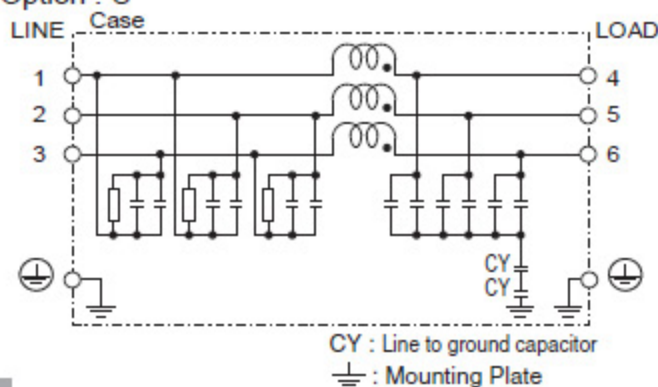

(4) Line to ground capacitor code : 155, 335
 Option : U

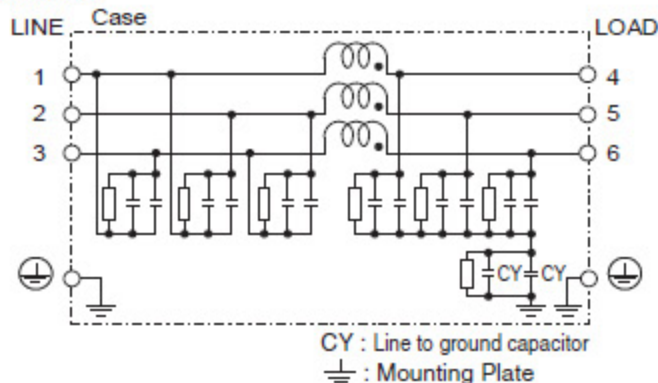

(5) Line to ground capacitor code : 155, 335
 Option : G

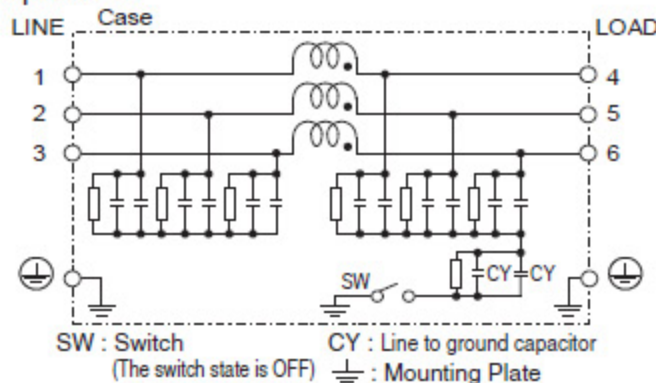

Derating Curve

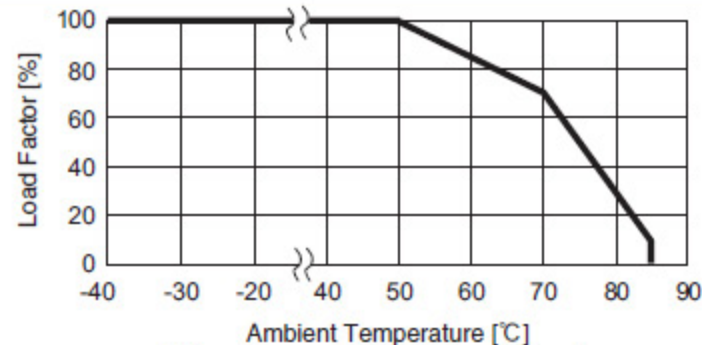

* Keep free ventilation holes for cooling.