

Single Cable Gland - PGLAND750\* Dimension Diagram unit:mm

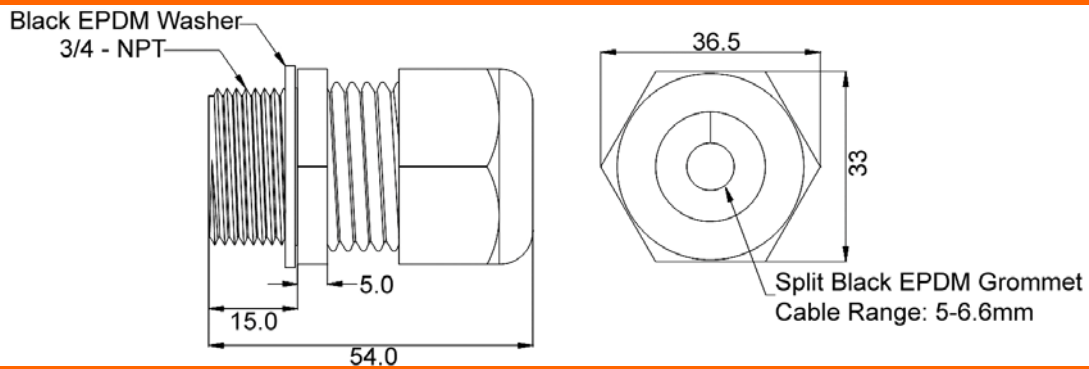

Double Cable Gland - PGLAND750-2\* Dimension Diagram unit:mm

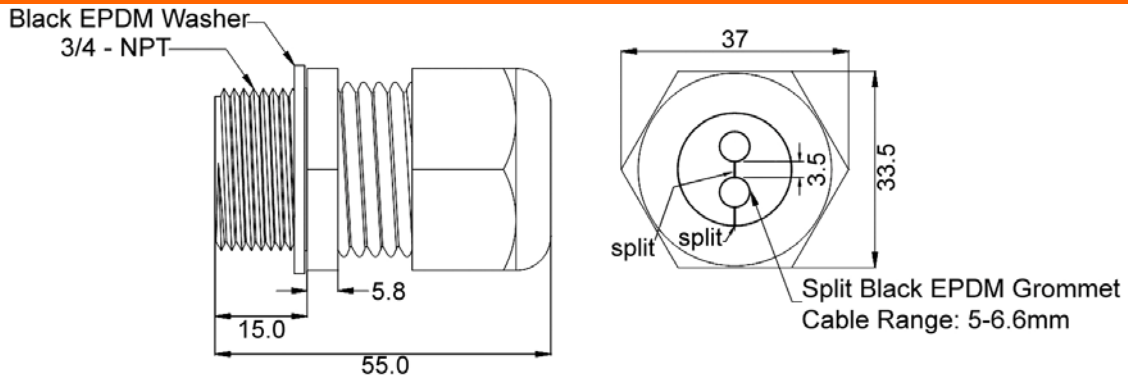

Note \*: Cable Glands are sold separately

**General** - Please read the following precautions carefully before installing and connecting the system to a power source.

**Note** – Only qualified and trained service personnel (in accordance with IEC 60950 and AS/NZS 3260) should install, replace, or service the equipment. Install the system in accordance with Country, National or to the U.S. National Electric Code if you are in the United States.

**Precautions:**

1. The building facilities in which the product will be used must provide Isolation to the main AC Input connector. This connection requires a fuse or circuit breaker no larger than 20A for 120 VAC (U.S.A.) or 16A, 230 VAC (international). The building facilities must protect the PoE33U Power injector from over current or short-circuits.
2. The POE33U power injector enclosure is IP67 tested which provides degrees of protection against access to hazardous parts, dust and against ingress of water. To ensure protection against ingress of water, torque captive screws (4 places) in an “X” pattern to > 27 inch pound. –Only qualified service personal should install, replace or service this equipment. Before connecting, visit “[www.midspans.com](http://www.midspans.com)” for the latest up to date specification and contact information.
3. The POE33U power injector enclosure must be mounted vertically but not orientation limited. The enclosure is provided with a steel 2mm thick zinc plated mounting bracket. When mounting utilize the holes in the mounting bracket plate (10mm holes) 8 places. The preferred method of mounting is to a vertical 4 inch or 6 inch pole using 2”3/8 x 16” U-bolts. If mounting on a flat surface, to sheetrock or wood and or others material, use 4 M6 fasteners. Other fasteners may be used, but hardware must be sized to support 4-5 times the weight of the unit.
4. The POE33U power injector enclosure has 3 threaded (3/4 NPT) openings to accommodate waterproof / water tight conduit and or cable glands. **WARNING:** To ensure protection against ingress of water, the connection(s) of the conduit and or cable glands are threaded with Teflon tape all the way through the holes in an enclosure wall.
5. The POE33U power injector AC input connector (located inside enclosure) is a 3 pin terminal block 9.5mm, rated 20 A, 250 V, with M3.5 Nickel Plated steel screws. The incoming 3 wire/cable must be minimum 14AWG and or in accordance with Country, National Electric Code.
6. The POE33U Power injector consists of “Data & Power” ports. The ports are providing TNV-1 outputs. The ports use RJ-45 data sockets. Do not connect telephone cables into these ports. Only RJ-45 data cables with waterproof / water tight connections may be connected to these sockets.
7. To prevent the POE33U Power injector from overheating, do not operate the product in an area that exceeds the maximum recommended ambient temperature of -40 °C to +60 °C.
8. Do not work on the POE33U Power injector or connect or disconnect cables, during periods of lightning activity.
9. The AC connector wire combination must be accessible at all times, as it serves as the main disconnect device to the product.
10. Before servicing the product, always disconnect the product from its AC source.
11. Equipment is for Pollution degree 2 Environment.
12. Disposal of this product should abide by all appropriate National laws and regulations.

- 1) The unit is packaged fully closed with the mounting bracket pre-installed; remove from packaging and loosen the four captive screws located at the top of the midspan so that the lid can be lifted easily.



- 2) Using a Philips screwdriver, remove the four screws holding the protective covering for the PC Board, and the two screws for the protective covering over the AC terminal block.



- 3) Connect cable glands (PGLAND750) or 3/4 NPT conduit piping to the face of the midspan. Ensure that connectors are fully installed to guarantee waterproof operation.



- 4) To better enable waterproof operation it is recommended that installers use Teflon tape to cover threads before installation. Users may also wish to use silicon sealant to further protect from ingress of liquid.



- 5) Thread outdoor rated waterproof AC cable (must comply with all local, national and country electrical codes) from source through piping/gland to the terminal block. The AC cable will need to be a minimum of 14AWG and terminated with M3.5 spade lugs. Pair and secure ground, line, and neutral to the appropriate positions on the three pin terminal block and reattach the protective covering. Note: if using the cable gland PGLAND750, the outer seal nut needs to be fully tightened to close rubber seal to protect against ingress of water.



- 6) Using waterproof outdoor rated Cat5e Ethernet cable, thread through cable glands or conduit piping to the appropriate RJ45 connector and ensure each portal is properly sealed.



- 7) Reattach the protective covering over the PC board and terminal blocks and re-close the lid. Ensure that the four captive screws are fully tightened before operation can commence.

